



LMC311 Air Handling Controller

Original document
Ver 2.0

LMC311 Modbus protocol description

Electrical skilled installer

Content

1.	Connection	3
2.	Setup	4
3.	Supported functions	4
4.	Register layout.....	5
4.1	Input registers	5
4.2	Holding registers	7
5.	Communication example	9
6.	Notes	10

I. Connection

The Modbus is wired to PIN 2,3,6 on connector CN7 located next to the USB plug on the LMC311 board.

Pin 1	12 VDC output
Pin 2	COM1 - RS 485 Data+ (A) - Modbus
Pin 3	COM1 - RS 485 Data- (/B) - Modbus
Pin 4	COM2 - RS 485 Data+ (A) – HMI350T
Pin 5	COM2 - RS 485 Data- (/B) – HMI350T
Pin 6	Ground

LMC311 Modbus connector:

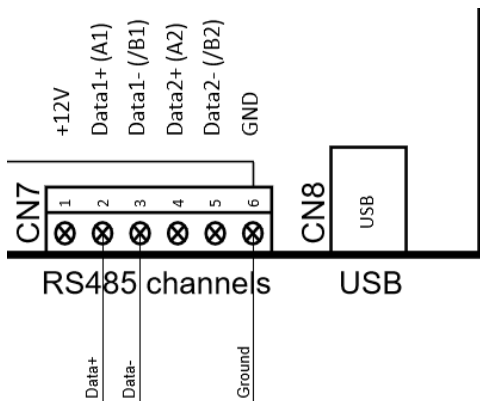

Point to point bus wiring:

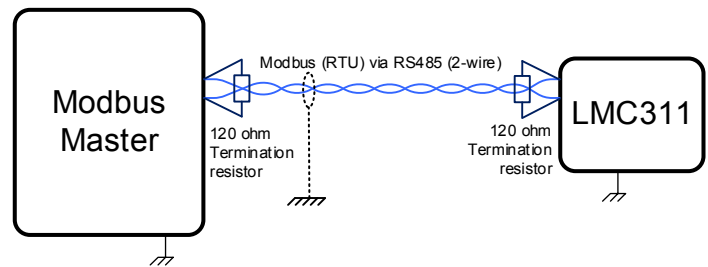

Cable specification:

Tinned twisted pair, with foil or braided shield, connected to ground only on the master side.

Max 200 m cable length.
 Characteristic impedance 100 - 130 Ohm.
 Shunt capacitance < 100 pF/m.
 AWG 24 / 0,25 mm².

Suggested types: Belden 941/942 or Multicable LIYCY-P 2*2*0,25 mm².

Common ground:

All network nodes must share a common ground connection as the bus signals shall refer to the same voltage potential.

There is no galvanic isolation on the LMC311 Modbus port.

Network termination:

120 Ohm resistors shall be connected between the two RS485 signal wires at each endpoint of the bus wire.

The resistor value shall match the characteristic impedance of the cable.

Receiver impedance >= 12 kOhm.

Linear bus wiring:

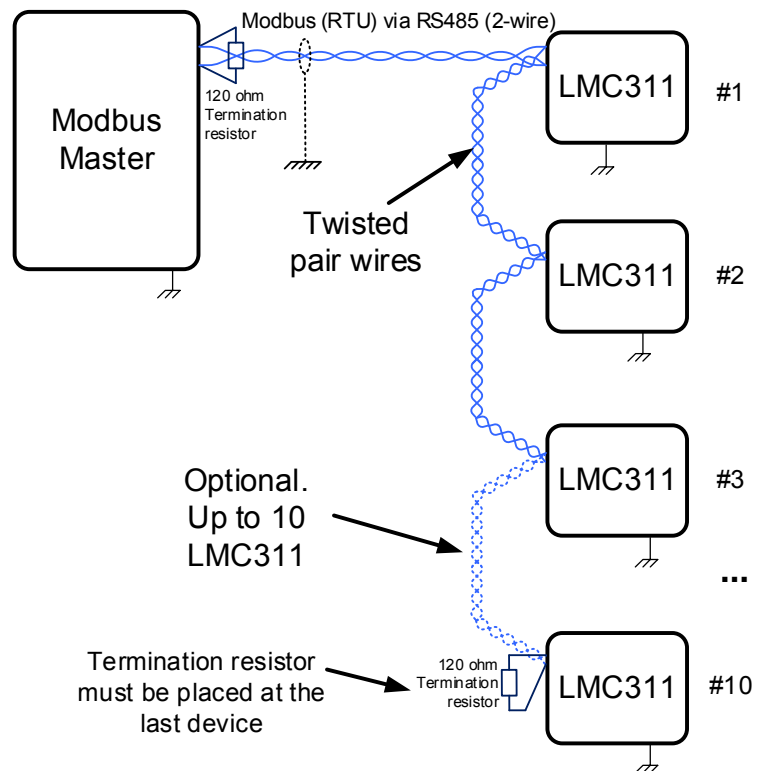

2. Setup

Protocol	Modbus (RTU mode), see http://www.modbus.org/specs.php
Node address	Default 30
Device type	LMC311 is a Modbus slave
Baud rate	19.200
Databits	8
Stopbits	1
Parity	Even
Packet size	Max. 255 bytes

3. Supported functions

Input and holding registers are supported.
 Unless otherwise specified, all registers are 16-bit size.

The controller will respond to the below listed Modbus message functions only.
 Please note that no other function codes are supported.

Function	Name	Description
03	Read Holding Registers	Read one or more holding registers
04	Read Input Registers	Read one or more input registers
16	Preset Multiple Registers	Write one or more holding registers

4. Register layout

Register addresses are given in decimal notation.

Input registers are located in the range 30001..39999.

Holding registers are located in the range 40001..49999.

NOTE:

In the tables below we list the register addresses as used in Modbus messages without the global offset.

That means if you read input register 100 with function code 04, you get the global address 30101.

NOTE:

All input registers can also be read as type holding register with function code 03 by adding the offset value 10000 to the register address. No writes will be accepted in this range.

4.1 Input registers

Name	Address	Scale	Unit	Description
Bus.Version	000			Protocol version number
App.VersionMajor	001	text		Software version - major (2 character ascii text)
App.VersionMinor	002	text		Software version - minor (2 character ascii text)
App.VersionRelease	003	text		Software version - release (2 character ascii text)
Input.UserFunc	100			User function
Input.AirFilter	101			Air filter alarm
Input.DoorOpen	102			Door contact
Input.Smoke	103			Smoke alarm
Input.MotorThermo	104			Motor thermo fuse
Input.Frost_Overht	105			Heating surface frost / overheat
Input.AirFlow	106			Airflow monitor
Input.T0_Controller	200	100	°C	Controller board temperature
Input.T1_Intake	201	100	°C	Fresh air intake temperature
Input.T2_Inlet	202	100	°C	Inlet temperature (before heater)
Input.T3_ Exhaust	203	100	°C	Room exhaust temperature
Input.T4_Outlet	204	100	°C	Outlet temperature
Input.T5_Cond	205	100	°C	Condenser temperature
Input.T6_Evap	206	100	°C	Evaporator temperature
Input.T7_Inlet	207	100	°C	Inlet temperature (after heater)
Input.T8_Outdoor	208	100	°C	Outdoor temperature
Input.T9_Heater	209	100	°C	Heating surface temperature
Input.T10_Extern	210	100	°C	External room temperature
Input.T11_Top	211	100	°C	Hot water top temperature
Input.T12_Bottom	212	100	°C	Hot water bottom temperature
Input.T13_Return	213	100	°C	Return temperature
Input.T14_Supply	214	100	°C	Supply temperature
Input.T15_Room	215	100	°C	User panel room temperature
AirQual.RH	221	100	%	Humidity sensor value
AirQual.CO2	222		ppm	Carbon dioxide sensor value
Input.Trotor	223	100	°C	Temperature after rotor
ActSupplySpeed	230		%	Supply fan speed
ActExtractSpeed	231		%	Exhaust fan speed
Alarm.Status	400			Alarm state bit mask 0x80 : Active alarm(s) are present 0x03 : Number of alarms listed
Alarm.List_1_ID	401			Alarm 1 - Code

Name	Address	Scale	Unit	Description
				0x80 : (reserved future use) 0x7F : Display code 1..99
Alarm.List_1_Date	402			Alarm 1 - Date Bit word packed in DOS date format Year 0 = 1980 15 8 7 0 YYYYYYM MMMDDDDD
Alarm.List_1_Time	403			Alarm 1 - Time Bit word packed in DOS time format Seconds are in scale 2 (0..29 = 0..58 seconds) 15 8 7 0 HHHHHMM MMMSSSS
Alarm.List_2_ID	404			Alarm 2 - Code
Alarm.List_2_Date	405			Alarm 2 - Date
Alarm.List_2_Time	406			Alarm 2 - Time
Alarm.List_3_ID	407			Alarm 3 - Code
Alarm.List_3_Date	408			Alarm 3 - Date
Alarm.List_3_Time	409			Alarm 3 - Time
Control.RunAct	1000			Actual on/off state 0 : Off 1 : On
Control.ModeAct	1001			Actual operation mode 0 : Off 1 : Heat 2 : Cool 3 : Auto 4 : Service
Control.StateDisplay	1002			Actual control state 0 : Off 1 : Shift 2 : Stop 3 : Start 4 : Standby 5 : Ventilation stop 6 : Ventilation 7 : Heating 8 : Cooling 13 : Defrost 14 : Frost secure 15 : Service 16 : Alarm
Control.SeclnState	1003		Sec	Actual time in state
AirTemp.IsSummer	1200			Summer state 0 : Off 1 : On
AirTemp.TempInletSet	1201	100	°C	Inlet temperature request (T7 setpoint)
AirTemp.TempControl	1202	100	°C	Actual value for controlled temperature
AirTemp.TempRoom	1203	100	°C	Actual room temperature (T15 or T10)
AirTemp.EffPct	1204	100	%	Passive heat exchanger efficiency calculation
AirTemp.CapSet	1205	100	%	Requested capacity
AirTemp.CapAct	1206	100	%	Actual capacity
HeatExtSet	1800	100	°C	Actual setpoint for external heating source
DPT.InSession	2200	0,1		1 if DPT node is in session
DPT.AirPress1	2201		Pa	DPT - Air diff pressure 1
DPT.AirPress2	2202		Pa	DPT - Air diff pressure 2

4.2 Holding registers

Name	Address	Scale	Unit	Description
Bus.Address	0			Protocol node address (default = 30)
Output.AirFlap	100			Air flap
Output.SmokeFlap	101			Smoke flap
Output.BypassOpen	102			Bypass flap open
Output.BypassClose	103			Bypass flap close
Output.AirHeatAllow	105			Air heating selected
Output.AirHeat	106			Air heater relay
Output.Rotor	130			Rotor exchanger on/off
Output.Supply	131			Supply fan
Output.Exhaust	132			Exhaust fan
Output.ExhaustSpeed	200	100	%	Exhaust fan speed
Output.InletSpeed	201	100	%	Supply fan speed
Output.AirHeatCap	202	100	%	Air heater capacity
Time.Second	300		ss	Second
Time.Minute	301		nn	Minute
Time.Hour	302		hh	Hour
Time.Day	303		dd	Day
Time.Month	304		mm	Month
Time.Year	305		yyyy	Year
Alarm.Reset	400			Clear one specific alarm code or all 0 : No command 1..99 : (reserved internal commands) 101..199 : Clear alarm display code 1..99 255 : Clear all alarms
Program.Select	500			Week program nb. select 0 : None 1 : Program 1 2 : Program 2 3 : Program 3 4 : Erase
PartyModeCountdown	550			Party mode countdown
PartyMode	551			Party mode 1 : Start/running 2 : Stop
Program.UserFuncAct	600			User function active (See "UserFuncSet")
Program.UserFuncSet	601			User function select 0 : None 1 : Extend 2 : Inlet 3 : Exhaust 4 : External heater offset 5 : Ventilate 6 : Cooker Hood
Program.UserTimeSet	602		Min	User function period
Program.UserVentSet	603		Step	User function ventilation step select 0 : Off 1..4 : Step number
Program.UserTempSet	604		°C	User function temperature (Extend function only)
Program.UserOffsSet	605		°C	User function temperature offset (Offset function only)

Name	Address	Scale	Unit	Description
Program.User2FuncAct	610			Same as user function 1 above
Program.User2FuncSet	611			--
Program.User2TimeSet	612			--
Program.User2VentSet	613			--
Program.User2TempSet	614			--
Program.User2OffsSet	615			--
Control.RunSet	1001			User on / off select 0 : Off (user input functions can still activate operation) 1 : On
Control.ModeSet	1002			User operation mode select 0 : Off 1 : Heat (no cooling active) 2 : Cool (no heating active) 3 : Auto 4 : Service (read only - write to register 1005)
Control.VentSet	1003		Step	User ventilation step select 0 : Off 1..3 : Step number
Control.TempSet	1004	100	°C	User temperature setpoint
Control.ServiceMode	1005			Service mode select 0 : Off 1 : Defrost 2 : Flaps 3 : Inlet 4 : Exhaust
Control.ServicePct	1006	100	%	Service mode capacity setpoint
Control.Preset	1007			Request preset to default settings 0 : Ready 1 : Standard (to factory defaults) 2 : Backup (to user file) 3 : Restore (from user file)
AirTemp.TempMinSum	1201	100	°C	Inlet temp. min. summer
AirTemp.TempMinWin	1202	100	°C	Inlet temp. min. winter
AirTemp.TempMaxSum	1203	100	°C	Inlet temp. max. summer
AirTemp.TempMaxWin	1204	100	°C	Inlet temp. max. winter
AirTemp.TempSummer	1205	100	°C	Summer/winter limit
AirQual.RH_VentLo	1910		Step	Humidity low winter step select
AirQual.RH_VentHi	1911		Step	Humidity high step select
AirQual.RH_LimLo	1912	100	%	Humidity limit for low ventilation
AirQual.RH_TimeOut	1913		min	Humidity max. time on high ventilation
AirQual.CO2_VentHi	1920		Step	CO2 high step select
AirQual.CO2_LimLo	1921		ppm	CO2 limit for normal ventilation
AirQual.CO2_LimHi	1922		ppm	CO2 limit for high ventilation

5. Communication example

The sample shown below is a general Modbus communication example and is not specific for this device.

Request: 0b041000000e75a4

Response: 0b041cffff0000095008b0e4a80014000b000108e108f1ffff000f0002fff39f8e

Request (Input register)

0x0b	Slave addr	1 byte
0x04	Function code	1 byte
0x1000	Start addr	2 bytes
0x000e	Quantity	2 bytes
0x75a4	CRC	2 bytes

Response

0x0b	Addr	1 byte
0x04	Function code	1 byte
0x1c	NB bytes of data	1 byte
0xffff	Value1	2 bytes
0x0000	Value2	2 bytes
0x0950	Value3	2 bytes
0x08b0	Value4	2 bytes
0xe4a8	Value5	2 bytes
0x0014	Value6	2 bytes
0x000b	Value7	2 bytes
0x0001	Value8	2 bytes
0x08e1	Value9	2 bytes
0x08f1	Value10	2 bytes
0xffff	Value11	2 bytes
0x000f	Value12	2 bytes
0x0002	Value13	2 bytes
0xff3	Value14	2 bytes
0x9f8e	CRC	2 bytes

Request: 0b03200000018f60

Response: 0b030200002045

Request (Holding register)

0x0b	Slave addr	1 byte
0x03	Function code	1 byte
0x2000	Address	2 bytes
0x0001	Quantity	2 bytes
0x8f60	CRC	2 bytes

Response

0x0b	Slave addr	1 byte
0x03	Function code	1 byte
0x02	Quantity	1 byte
0x0000	Value1	2 bytes
0x2045	CRC	2 bytes



Ver. 2.0 11.2021

Subject to change