

- AT** = Operation temperature sensor
- EAT** = Extract air sensor
- UTE** = Fresh air sensor/ Defrost sensor
- AVK** = Rotor guard sensor

- RH%** = Humidity sensor

- MC** = Control box
- CP** = Control panel

- TV** = Inlet fan
- AV** = Extract fan

- EV** = Reheater battery
- BT** = Fire thermostat
- OET** = Overheat temperature sensor

- RM** = Rotor motor
- RO** = Rotary heat exchanger

- CO²** = CO² Sensor (Option)
- D¹** = Impulse switch (Option)
- D²** = External humidity sensor (Option)
- D³** = Home / Leave (Option)
- KV** = Cookerhood
- F** = Filter

- LB** = Light bulb in cookerhood
- S1** = Switch for lightbulb in cookerhood
- S2** = Timer switch for cookerhood

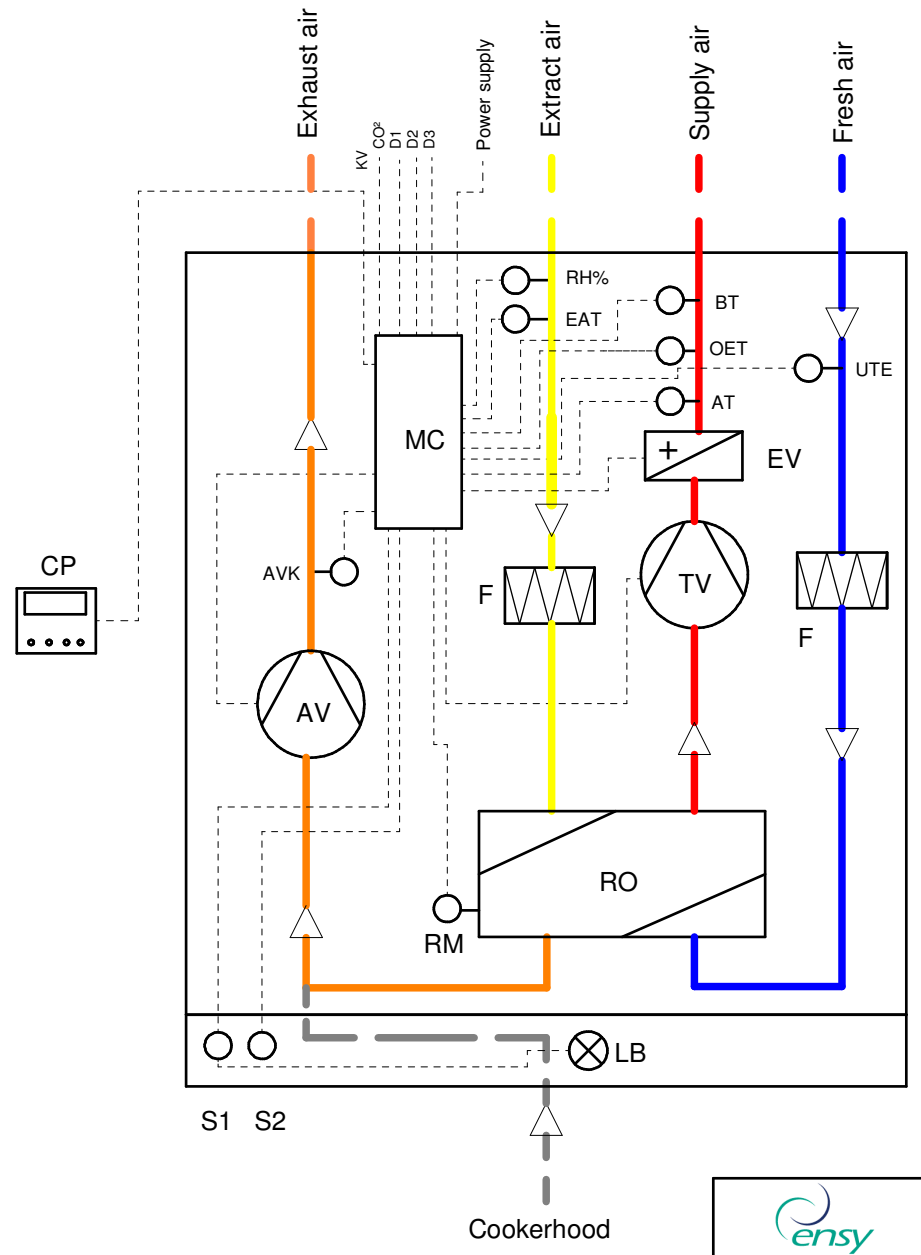

Art no: 0100004-2
 Art no: 0100006-2
 Art no: 0100008-2
 Art no: 0100010-2

		Material:	Art. no.: see above
		Dim.:	Tolerance:
Drawn 21.12.2016 knkl		Systemskjema Ensy	
Checked		AHU-200 KH	
Scale 1:1 A3		Drawing number	
Filename Ensy AHU-200 KH.idw		Ensy AHU-200 KH	
			Page 1-1