

- AT** = Operation temperature sensor
- EAT** = Extract air sensor
- UTE** = Fresh air sensor/ Defrost sensor
- AVK** = Rotor guard sensor

- RH%** = Humidity sensor

- MC** = Control box
- CP** = Control panel in front door
- CP2** = Extra Control panel (Option)

- TV** = Inlet fan
- AV** = Extract fan

- EV** = Reheater battery
- BT** = Fire thermostat
- OET** = Overheat temperature sensor

- RM** = Rotor motor
- RO** = Rotary heat exchanger

- KV** = Cookerhood
- CO²** = CO² Sensor (Option)
- D¹** = Impulse switch (Option)
- D²** = External humidity sensor (Option)
- D³** = Home / Leave (Option)

- F** = Filter

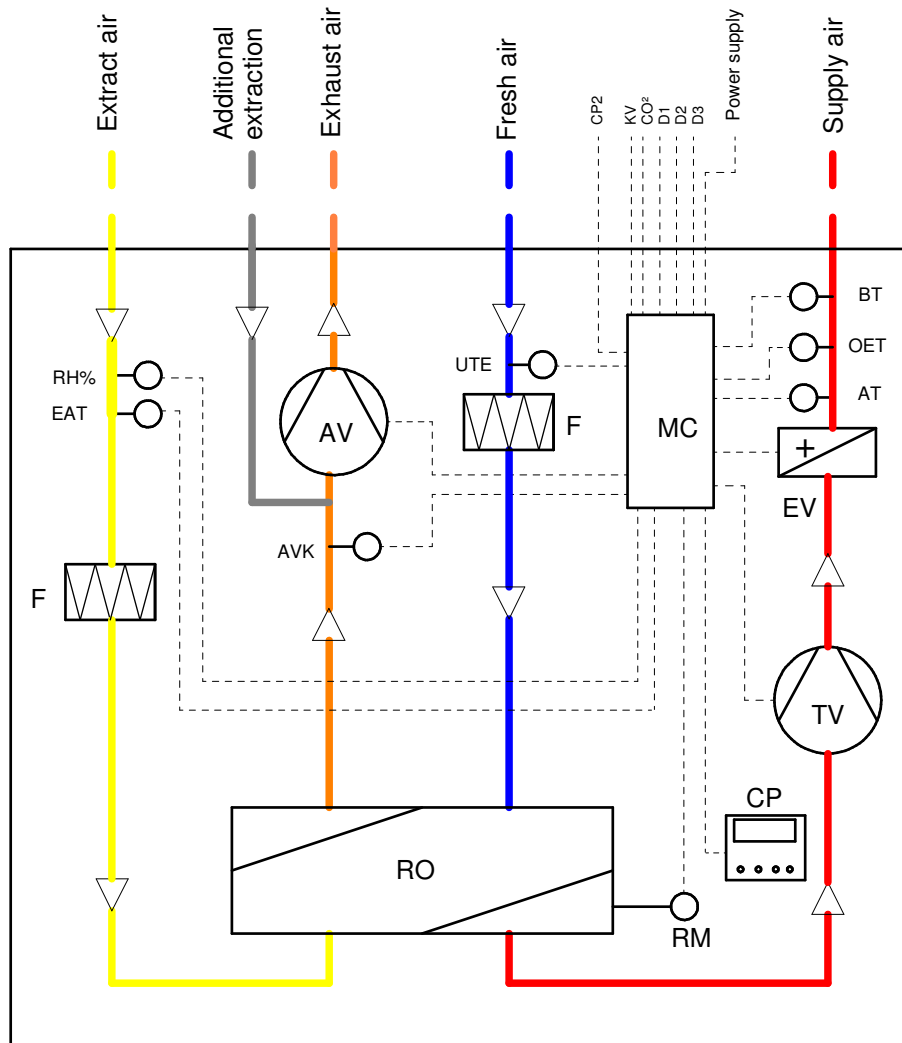

| | | | |
|---|-----|--------------------------|--------------------|
|  | | Material: | Art. no.:0101901-2 |
| | | Dim.: | Tolerance: |
| | | Systemskjema Ensy | |
| | | AHU-350 BH | |
| | | Drawing number | |
| | | Ensy AHU-350 BH | |
| | | Page | |
| | | 1 - 1 | |
| Scale | 1:1 | A3 | |
| Filename Ensy AHU-350 BH.idw | | | |

| Date | Name |
|------------|------|
| 21.12.2016 | knkl |
| | |
| | |
| | |