

- AT** = Operation temperature sensor
- EAT** = Extract air sensor
- UTE** = Fresh air sensor/ Defrost sensor
- AVK** = Rotor guard sensor

- RH%** = Humidity sensor

- MC** = Control box
- CP** = Control panel in front door
- CP2** = Extra Control panel (Option)

- TV** = Inlet fan
- AV** = Extract fan

- EV** = Reheater battery
- BT** = Fire thermostat
- OET** = Overheat temperature sensor

- RM** = Rotor motor
- RO** = Rotary heat exchanger

- KV** = Cookerhood
- CO²** = CO² Sensor (Option)
- D¹** = Impulse switch (Option)
- D²** = External humidity sensor (Option)
- D³** = Home / Leave (Option)
- F** = Filter

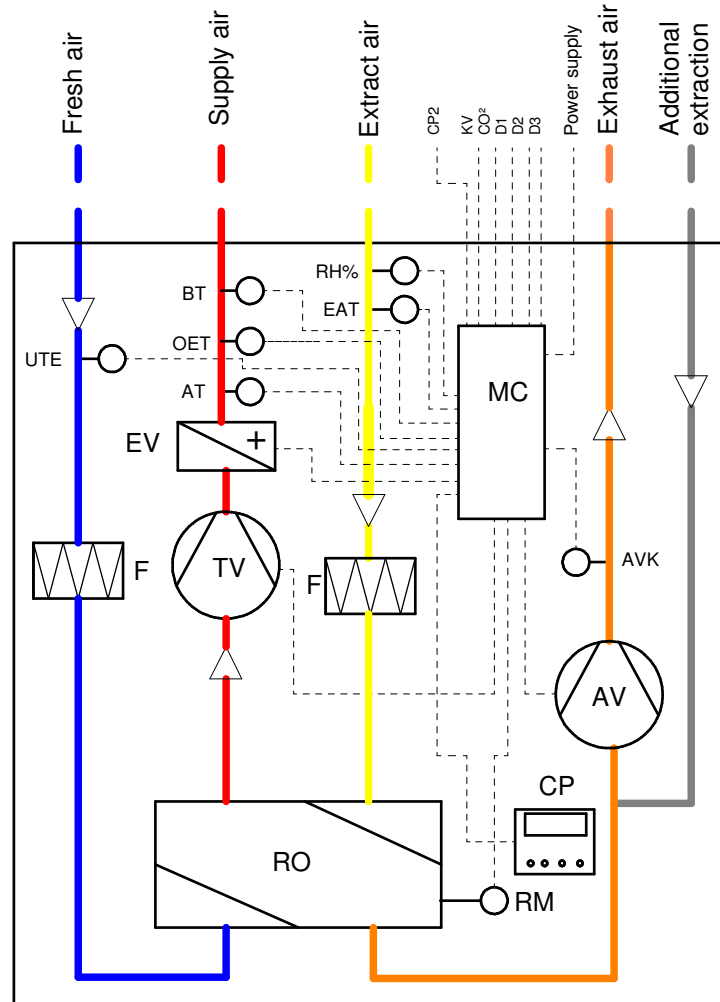

| | | | | | |
|---|------------|------|----------------|--------------------|--|
|  | | | Material: | Art. no.:0100003-2 | |
| | | | Dim.: | Tolerance: | |
| Systemskjema Ensy | | | AHU-200 V | | |
| Drawn | 30.11.2016 | knkl | | | |
| Checked | 19.12.2016 | knkl | Drawing number | | |
| Ensy AHU-200 V | | | Page | | |
| Scale 1:1 A3 | | | 1 - 1 | | |
| Filename Ensy AHU-200 V.idw | | | | | |