

- AT** = Operation temperature sensor
- EAT** = Extract air sensor
- UTE** = Fresh air sensor/ Defrost sensor
- AVK** = Rotor guard sensor

- RH%** = Humidity sensor

- MC** = Control box
- CP** = Control panel in front door
- CP2** = Extra Control panel (Option)

- TV** = Inlet fan
- AV** = Extract fan

- EV** = Reheater battery
- BT** = Fire thermostat
- OET** = Overheat temperature sensor

- RM** = Rotor motor
- RO** = Rotary heat exchanger

- KV** = Cookerhood
- CO²** = CO² Sensor (Option)
- D¹** = Impulse switch (Option)
- D²** = External humidity sensor (Option)
- D³** = Home / Leave (Option)
- F** = Filter

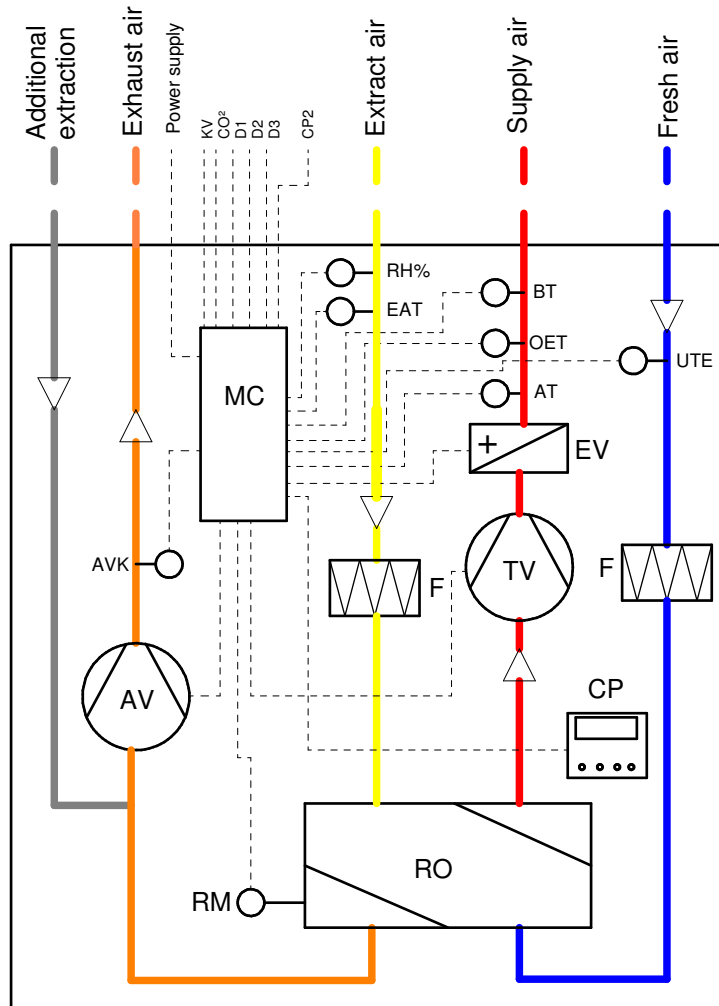

		Material:	Art. no.:01000002-2						
		Dim.:	Tolerance:						
<table border="1"> <thead> <tr> <th>Date</th> <th>Name</th> </tr> </thead> <tbody> <tr> <td>30.11.2016</td> <td>knkl</td> </tr> <tr> <td>19.12.2016</td> <td>knkl</td> </tr> </tbody> </table>		Date	Name	30.11.2016	knkl	19.12.2016	knkl	Systemskjema Ensy AHU-200 H	
		Date	Name						
		30.11.2016	knkl						
19.12.2016	knkl								
Drawing number Ensy AHU-200 H		Page 1 - 1							
Scale	1:1	A3							
Filename Ensy AHU-200 H.idw									